



GOCE/GRACE GGM evaluation over Attika and Thessaloniki, Greece and local geoid modeling in support of height unification

I.N. Tziavos¹, G.S. Vergos¹, V.D. Andritsanos², V.N. Grigoriadis¹, V. Pagounis²

¹Department of Geodesy and Surveying, Aristotle University of Thessaloniki, Greece, tziavos@topo.auth.gr



²Department of Civil Engineering and Surveying & Geoinformatics Engineering, Technological Educational Institute of Athens, Greece

1. Introduction and Problem

Within the frame of the "Elevation" project, supported by the action "Archimedes III – Funding of research groups in T.E.I.", co-financed by the E.U. and Greek national funds, an extensive evaluation of the latest GOCE, GOCE/GRACE and combined GGMs has been carried out. The evaluation was performed using a set of collocated GPS and leveling BMs covering the regions of Attika and Thessaloniki. To this extent all available satellite-only and combined GOCE/GRACE GGMs were evaluated to conclude on the possible improvement brought by GOCE, given the various methodologies used for the GGM development (DIR, TIM, SPW, GOCO, EIGEN) and the various releases of GOCE data (Release 1, 2, 3, 4 and 5). For the latest GGMs, local height transformation parameters have been determined to accommodate surveying and engineering applications. Moreover, local geoid models have been determined for the two areas under study through the well-known Multiple-Input Multiple-Output System Theory (MIMOST) method, employing GOCE GGMs and the local GPS/Levelling data. The so-determined geoid models are validated against the latest gravimetric geoid for Greece and conclusions are drawn w.r.t. the improvement brought by GOCE in resolving the lower and medium band of the gravity field spectrum with higher accuracy.

3. Evaluation of geoid heights derived from GGMs

Absolute differences between the geoid heights and the GPS/leveling benchmarks were computed for each test area using the following formula:

$$\Delta N_i^{abs} = N_i^{GPS/lev} - N_i^{GGM} - N_i^0$$

where N_i^0 is the contribution of the zero-degree harmonic to the GGM geoid undulations with respect to a specific reference ellipsoid. The statistical values of the differences (before fit) are provided in Table 2.

A least-squares adjustment procedure was then carried out using six parametric models list below:

$$A: \alpha_i^T x = x_0 + x_1 \cos \varphi_i \cos \lambda_i + x_2 \cos \varphi_i \sin \lambda_i + x_3 \sin \varphi_i$$

$$B: \alpha_i^T x = x_0 + x_1 \cos \varphi_i \cos \lambda_i + x_2 \cos \varphi_i \sin \lambda_i + x_3 \sin \varphi_i + x_4 \sin^2 \varphi_i$$

$$C: \alpha_i^T x = \mu + \delta S_H H_i + \delta S_N N_i$$

$$D: \alpha_i^T x = \mu + \delta S_H H_i$$

$$E: \alpha_i^T x = \mu + \delta S_N N_i$$

$$F: \alpha_i^T x = \sum_{m=0}^2 \sum_{n=0}^2 x_{(3m+n)} (\varphi_i - \varphi_0)^n (\lambda_i - \lambda_0)^m \cos^m \varphi_i$$

where x_j {j:1,...,6}, δS_H and δS_N are the model coefficients, φ_i and λ_i denote the geographical latitude and longitude, respectively, and φ_0 and λ_0 are the corresponding mean geodetic latitude and longitude of the study area.

Table 2: Statistics of geoid height differences between GPS/leveling geoid heights and GGMs geoid heights before and after the least-squares fit with parametric models for the areas of Attika and Thessaloniki.

Geoid Model	Parametric Model	Attika				Thessaloniki			
		mean [m]	std [m]	range [m]	R_{adj}^2	mean [m]	std [m]	range [m]	R_{adj}^2
DIR-R5 max deg: 140	Before Fit	-0.575	0.334	1.476	-	-0.765	0.447	2.241	-
	Model A	0.008	0.177	0.819	0.727	0.066	0.243	1.354	0.691
	Model B	0.000	0.173	0.823	0.744	0.000	0.239	1.338	0.723
	Model C	0.000	0.250	1.097	0.452	0.000	0.314	1.616	0.513
	Model D	0.000	0.333	1.437	0.018	0.000	0.331	1.746	0.456
	Model E	0.000	0.286	1.388	0.278	0.000	0.445	2.201	0.017
DIR-R5 max deg: 300	Before Fit	-0.262	0.187	0.887	-	-0.528	0.472	2.396	-
	Model F	0.000	0.115	0.538	0.648	0.000	0.180	1.088	0.864
DIR-R5 (deg 140 + EGM08)	Before Fit	-0.406	0.080	0.514	-	-0.488	0.160	1.014	-
	Model F	0.000	0.072	0.397	0.255	0.000	0.141	0.738	0.269
TIM-R5 max deg: 140	Before Fit	-0.563	0.336	1.535	-	-0.768	0.449	2.250	-
	Model F	0.000	0.122	0.524	0.879	0.000	0.180	1.088	0.850
TIM-R5 max deg: 280	Before Fit	-0.293	0.202	0.989	-	-0.671	0.446	2.253	-
	Model F	0.000	0.116	0.543	0.698	0.000	0.180	1.095	0.847
TIM-R5 (deg 140 + EGM08)	Before Fit	-0.394	0.080	0.776	-	-0.491	0.160	0.731	-
	Model F	0.000	0.072	0.397	0.258	0.000	0.141	0.738	0.272

4. Input-Output geoid models

The use of a "2 inputs – 1 output" system is introduced. Random noise field of 10 cm sd is assumed for both input data as the optimal transfer function of the system is estimated. Geoid heights using DIR-R5 to a max. deg. 140 and EGM08 residual signal have been combined optimally with geoid heights from GPS/leveling. The final geoid solution is estimated through an optimal spectral combination of the input signal (minimization of output error).

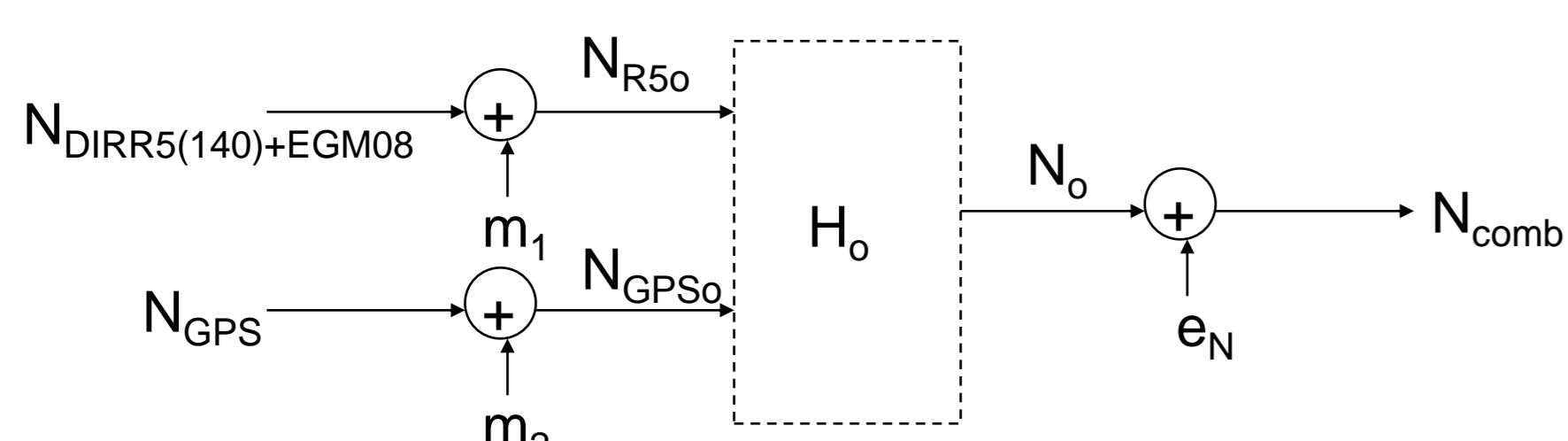

Figure 4: Schematic representation of the input – output system used in the computations of the combined geoid

The estimation of the output error PSD is feasible through the error propagation in the frequency domain. The error PSD can be transformed to output error covariance in 2D by the application of an inverse FFT transformation.

$$\hat{H}_0 = P_{xy} (P_{yy} + P_{mm})^{-1} = P_{xy} P_{y_0 y_0}^{-1}$$

$$\hat{X}_0 = \hat{H}_0 Y_0 = H_{xy} (P_{y_0 y_0} - P_{mm})^{-1} P_{y_0 y_0}^{-1} Y_0$$

$$P_{\hat{e}\hat{e}} = [H_{xy} (P_{y_0 y_0} - P_{mm}) - \hat{H}_0 P_{y_0 y_0}] (H_{xy}^{*T} - \hat{H}_0^{*T}) + \hat{H}_0 P_{mm} H_{xy}^{*T}$$

$$C_{\hat{e}\hat{e}} = F^{-1} \{ P_{\hat{e}\hat{e}} \}$$

2. Available data and models

The GGMs used in the evaluation procedure are listed in Table 1, while the distribution of the geoid heights (103 values for Attika and 127 values for Thessaloniki) obtained from GPS/leveling measurements are shown in Figure 1.

Table 1: List of used GGMs

Model	n_{max}	Data	Reference
DIR-R5	300	S(GOCE, GRACE, LAGEOS)	Bruinsma et al, 2013
TIM-R5	280	S(GOCE)	Brockmann et al., 2014
EGM08	2190	S(GRACE), G, A	Pavlis et al., 2012

Data: S = Satellite tracking, G = Gravity, A = Altimetry

Figure 1: Distribution of the GPS/leveling data for Thessaloniki (right) and Attika (left). The colored values depict differences between geoid heights from TIM-R5 (max deg 140) and those derived from GPS/leveling data.

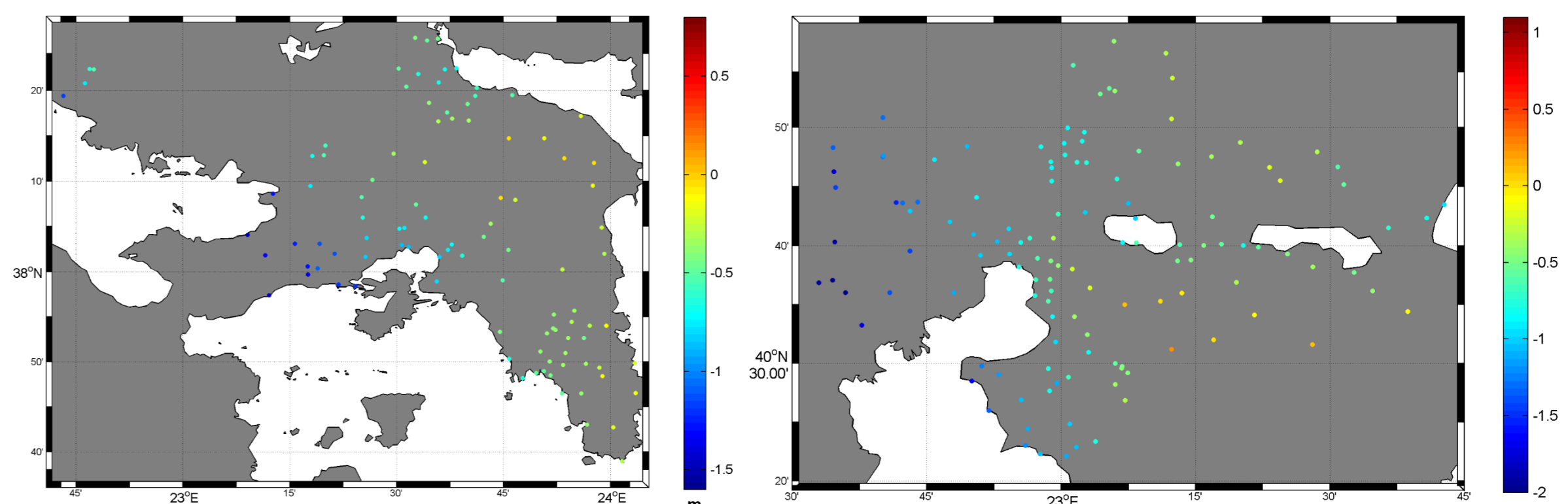

From the results provided in Table 2, it is observed that the differences in Thessaloniki are larger than the ones observed in Attika in terms of standard deviation, mean value and range. A possible explanation for these differences is directly related to the vertical network of Greece. The benchmarks for the area of Attika are close to the reference point of the Greek vertical datum, i.e., the tide gauge station at Piraeus port. On the other hand, the benchmarks located in the area of Thessaloniki lie approximately more than 300 km away from the reference point and a common adjustment of the Greek vertical network has never been carried out so far. By further examining the results the third order polynomial model (model F) seems to provide the best fitting results for both test areas. In the case where the two GOCE-based models DIR-R5 and TIM-R5 are combined with EGM08, the parametric models provide an improvement to the results of approximately 1 cm for Attika in terms of standard deviation and 2 cm for Thessaloniki.

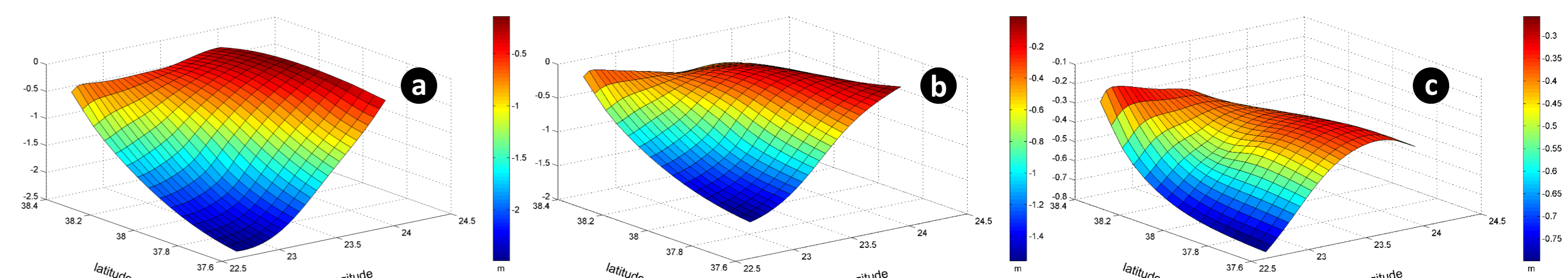

Figure 2: Corrector surface computed for the area of Attika using a third order polynomial parametric model (model F) for the differences between geoid heights from GPS/leveling and the geoid models: a) TIM-R5 (max degree 140), b) TIM-R5 (max degree 280), c) combination of TIM-R5 (max degree 140) and EGM08

In Figure 2 indicative plots are shown for the estimated corrector surfaces for the area of Attika using a third order polynomial parametric model (model F). The corrector surfaces for model F depict a south-west to north-east trend, while for the area of Thessaloniki no such trend is detected.

Table 3: Statistics of geoid height differences between GPS/leveling geoid heights, GGMs geoid heights and combined MIMOST geoid heights for the areas of Attika and Thessaloniki.

Area	$N_{GPS/lev.} - N_{DIR-R5(140)+EGM08}$			$N_{GPS/lev.} - N_{comb}$		
	mean [m]	std [m]	range [m]	mean [m]	std [m]	range [m]
Attika	-0.406	0.080	0.514	-0.572	0.067	0.412
Thessaloniki	-0.488	0.160	1.014	-0.659	0.125	0.632

Figure 5: Distribution of the GPS/leveling data for Thessaloniki (right) and Attika (left). The colored values depict differences between geoid heights from combined MIMOST solution and those derived from GPS/leveling data.

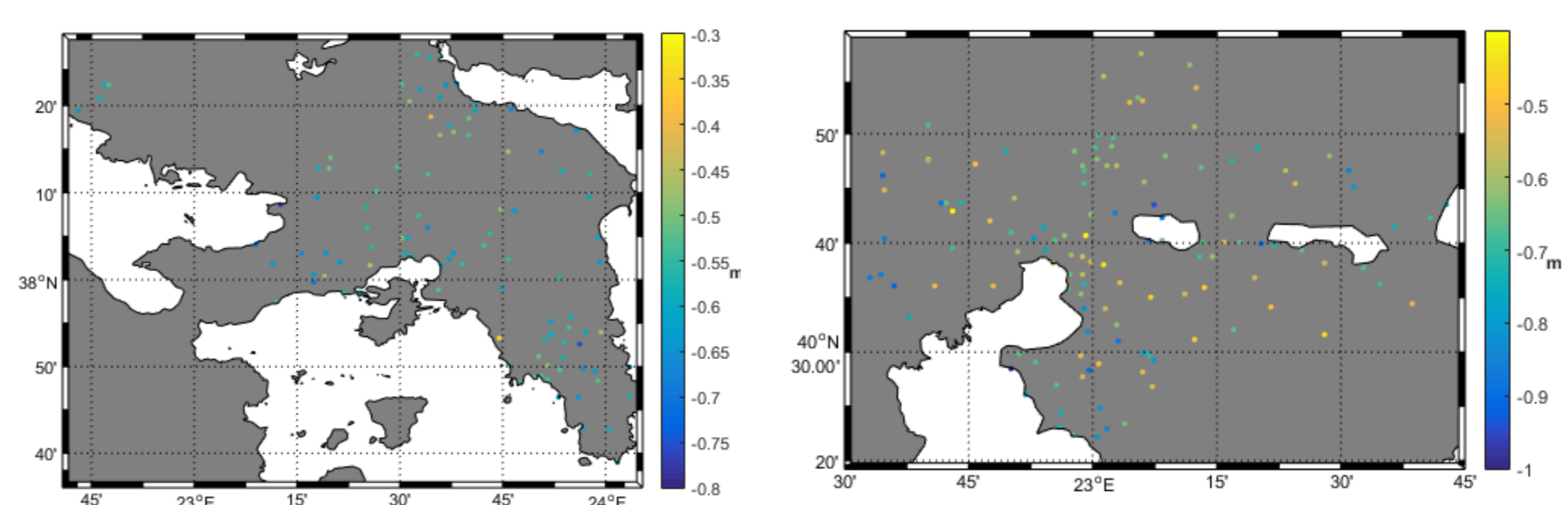
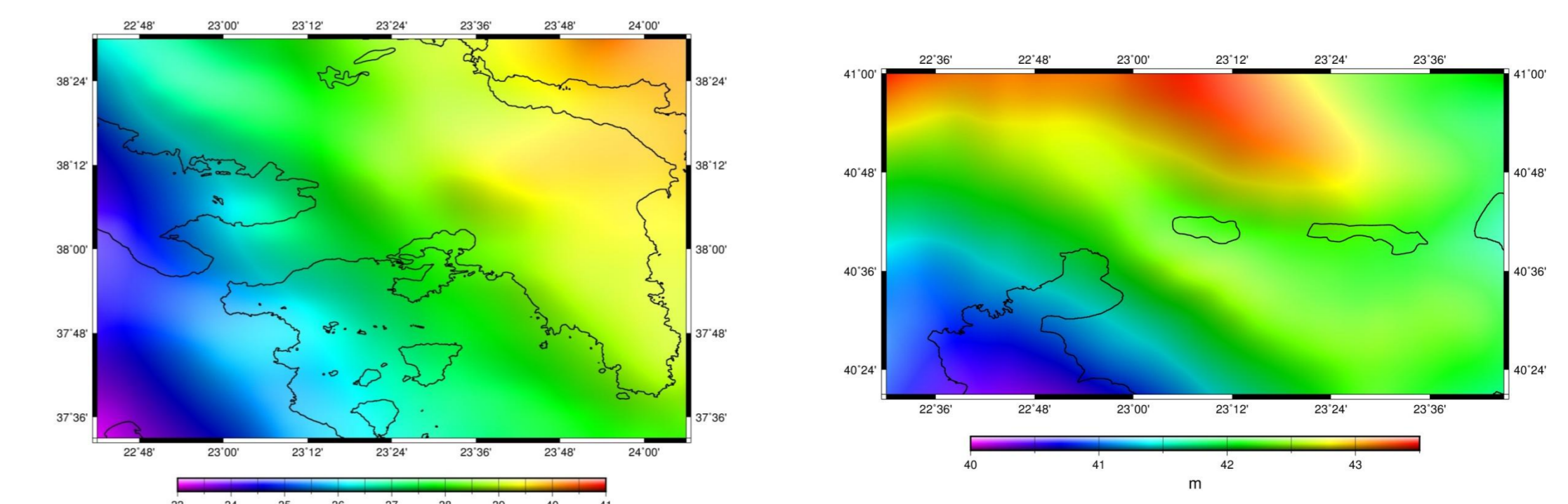

Figure 6: Combined MIMOST estimated geoid for Thessaloniki (right) and Attika (left).



5. Conclusions

The extensive evaluation of the latest GOCE, GOCE/GRACE and combined GGMs have been carried out using GPS/leveling benchmarks at two regions in Central (Attika) and Northern (Thessaloniki) Greece. Local parametric models have been tested in order to remove all datum inconsistencies. Six parametric models have been selected and GGMs signal has been used to its maximum power, as well as to a truncation limit. The GOCE/GRACE GGMs signal has been filled in by the contribution of EGM08 frequency content. The 5th release of GOCE models estimated by the Direct as well as the Time-Wise approach and filled by EGM08 signal outperformed any other case, in terms of the standard deviation and the range of the differences at GPS benchmarks. A third order polynomial improved the results of the differences by 1 cm in Attika and 2 cm in Thessaloniki area, in terms of standard deviation. A combined GPS/leveling/GGM geoid model using the geoid information from GOCE DIR-R5 to a degree 140 and EGM08 residual signal has been estimated using MIMOST. The comparisons showed an improvement of 1.3 cm in Attika and 3.5 cm in Thessaloniki to the statistics of the standard deviation before fit. The incorporation of GPS/leveling signal to the final combined geoid is feasible through MIMOST.

